

ELEKTRA

heating cables

- Manufactured according to directives of the International Electrotechnical Commission: IEC STANDARD Publication 800 - heating cables for a nominal current of 300/500V used in the heating of rooms as well as freezing prevention;
- Certified by the BBJ SEP (Quality Test Office of the Association of Electrical Engineers) and certified for use in construction industry;
- Manufactured according to the ISO 9001 Quality Assurance System.



Applications

- Floor heating for houses and apartments, summer cottages, garages, storages, stores, churches - as the basic heating system;
- Floor heating for selected compartments such, as additional heating for stone floors in bathrooms, kitchens, living rooms, workshops...
- Heating for greenhouses, pigsties, farms, cold storages;
- Anti-freezing protection for gutters, down pipes, pipelines, water tanks;
- Protection against icing for ramps, walkways, stairways, porches, terraces.

A Advantages of floor heating

COMFORT

- All you should do is to regulate or preset the temperature you require;
- Uniform temperature in all rooms and compartments;
- Low temperature of the heating surface;
- Your floor is warm in a short time;

NEAT DESIGN

- The heating equipment is invisible;
- No more dirty compartments (boiler room, etc.);

HEALTH

- Perfect thermal comfort: walls and ceiling are uniformly warm, temperature is uniform across each compartment;

SAFETY

- The cable is screened on its entire length;
- The screen is effectively grounded;
- The differential switch eliminates electric shock hazard;

EXPENSES

- Expenditures for the system installation are exceptionally low compared to traditional systems;
- Low energy costs due to the precise temperature regulation.

ELEKTRA heating cable types

ELEKTRA single-core or double-core heating cables are manufactured in ready-to-install sets of length between 4 and 318 meters and heating power between 70 W and 4500 W. The nominal supply voltage is 220/230 VAC 50 Hz.

Double-core cables (single-side power supply)

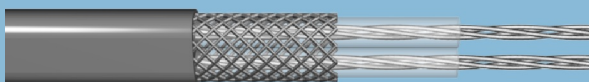

Table 1

CABLE TYPE		10 W/m		CABLE TYPE		17 W/m		CABLE TYPE		25 W/m	
DOUBLE-CORE CABLES	LENGTH	POWER	DOUBLE-CORE CABLES	LENGTH	POWER	DOUBLE-CORE CABLES	LENGTH	POWER	DOUBLE-CORE CABLES	LENGTH	POWER
SYMBOL	m	W	SYMBOL	m	W	SYMBOL	m	W	SYMBOL	m	W
VCD 10/70	7	70	VCD 17/100	6	100	VCD 25/100	4	100			
VCD 10/90	9	90	VCD 17/135	8	135	VCD 25/175	7	175			
VCD 10/110	11	110	VCD 17/170	10	170	VCD 25/250	10	250			
VCD 10/130	13	130	VCD 17/220	13	220	VCD 25/300	12	300			
VCD 10/170	17	170	VCD 17/255	15	255	VCD 25/350	14	350			
VCD 10/200	20	200	VCD 17/285	17	285	VCD 25/400	16	400			
VCD 10/230	23	230	VCD 17/340	20	340	VCD 25/475	19	475			
VCD 10/260	26	260	VCD 17/390	23	390	VCD 25/550	22	550			
VCD 10/310	31	310	VCD 17/460	27	460	VCD 25/650	26	650			
VCD 10/360	36	360	VCD 17/530	31	530	VCD 25/700	28	700			
VCD 10/410	41	410	VCD 17/595	35	595	VCD 25/875	35	875			
VCD 10/460	46	460	VCD 17/710	42	710	VCD 25/1100	44	1100			
VCD 10/550	55	550	VCD 17/915	54	915	VCD 25/1425	57	1425			
VCD 10/710	71	710	VCD 17/1170	69	1170	VCD 25/1750	70	1750			
VCD 10/900	90	900	VCD 17/1425	84	1425	VCD 25/1925	77	1925			
VCD 10/1100	110	1100	VCD 17/1595	94	1595	VCD 25/2250	90	2250			
VCD 10/1220	122	1220	VCD 17/1920	113	1920	VCD 25/2450	98	2450			
VCD 10/1470	147	1470	VCD 17/2040	120	2040	VCD 25/2750	110	2750			
VCD 10/1560	156	1560	VCD 17/2260	133	2260	VCD 25/3000	120	3000			
VCD 10/1730	173	1730	VCD 17/2480	146	2480	VCD 25/3250	130	3250			
VCD 10/1900	190	1900	VCD 17/2720	160	2720	VCD 25/3550	142	3550			
VCD 10/2070	207	2070	VCD 17/2920	172	2920						
VCD 10/2250	225	2250									

ATTENTION: Values shown in the table may vary by up to 5%.
The 25W/m is for use in outdoor areas driveways, ramps, walkways, etc - as shown in table 2, page 6.

Single-core cables
(double-side power supply)



continuing Table I

10 W/m			15 W/m			20 W/m		
CABLE TYPE	10 W/m		CABLE TYPE	15 W/m		CABLE TYPE	20 W/m	
SINGLE-CORE CABLES	LENGTH	POWER	SINGLE-CORE CABLES	LENGTH	POWER	SINGLE-CORE CABLES	LENGTH	POWER
SYMBOL	m	W	SYMBOL	m	W	SYMBOL	m	W
VC 10/70	7	70	VC 15/90	6	90	VC 20/100	5	100
VC 10/95	10	95	VC 15/120	8	120	VC 20/140	7	140
VC 10/120	12	120	VC 15/150	10	150	VC 20/170	9	170
VC 10/145	15	145	VC 15/180	12	180	VC 20/205	10	205
VC 10/180	18	180	VC 15/220	15	220	VC 20/255	13	255
VC 10/230	23	230	VC 15/285	19	285	VC 20/320	16	320
VC 10/280	28	280	VC 15/345	23	345	VC 20/400	20	400
VC 10/320	32	320	VC 15/390	26	390	VC 20/460	23	460
VC 10/370	37	370	VC 15/450	30	450	VC 20/520	26	520
VC 10/440	44	440	VC 15/540	36	540	VC 20/620	31	620
VC 10/510	51	510	VC 15/630	42	630	VC 20/720	36	720
VC 10/580	58	580	VC 15/720	48	720	VC 20/820	41	820
VC 10/640	64	640	VC 15/795	53	795	VC 20/920	46	920
VC 10/780	78	780	VC 15/960	64	960	VC 20/1100	55	1100
VC 10/1010	101	1010	VC 15/1240	83	1240	VC 20/1420	71	1420
VC 10/1270	127	1270	VC 15/1560	104	1560	VC 20/1800	90	1800
VC 10/1550	155	1550	VC 15/1900	127	1900	VC 20/2200	110	2200
VC 10/1730	173	1730	VC 15/2110	141	2110	VC 20/2460	123	2460
VC 10/2080	208	2080	VC 15/2550	170	2550	VC 20/2920	146	2920
VC 10/2200	220	2200	VC 15/2700	180	2700	VC 20/3120	156	3120
VC 10/2450	245	2450	VC 15/3000	200	3000	VC 20/3460	173	3460
VC 10/2690	269	2690	VC 15/3300	220	3300	VC 20/3800	190	3800
VC 10/2940	294	2940	VC 15/3600	240	3600	VC 20/4140	207	4140
VC 10/3180	318	3180	VC 15/3900	260	3900	VC 20/4500	225	4500

ATTENTION! Data in the table may vary up to 5%

The ELEKTRA heating cable sets are manufactured in ready-to-install sets: precisely precut, tested and connected with the 2.5 metres cold tail (2 x 1.5 mm² - single-core cable with double-side supply or 3 x 1.5 mm² double-core cable with single-side supply).

ATTENTION: VCD double-core cables (single-side supply) are recommended for houses and apartments.

T Temperature control

The temperature controller is the indispensable element of any floor heating system. The temperature controller allows for a correct operation of the heating cable system. A correct selection of the controller provides you with the optimum heating result according to your requirements.

If you use the heating cables as just **a complement to your basic (existing) heating system**, then you may be interested in the "warm floor" effect (for instance in your bathroom) - for this, you should use the controller with floor temperature sensor. If the heating cables are the basic heat source, you are interested in an optimum air temperature in the entire apartment or house - and one of our air temperature controllers will be the best selection, in particular:

- a) temperature controller with air temperature sensor;
- b) temperature controller with air and floor temperature sensors (the unit controls the air temperature, while the floor sensor protects the heating cables and the floor against overheating).

We offer the following types of temperature controller:

- a) constant air temperature or floor temperature controllers,
- b) programmable controllers to provide you with a presetting option for an optimum temperature of your choice for the day, and another temperature for the night,
- c) air temperature controllers with a night-time temperature decrease.

ATTENTION: If the heating power of the system circuit does NOT exceed 2000 W, the temperature controller for 10 A nominal current should be used; if the power exceeds 2000 W, the temperature controller for 16 A nominal current must be used.

Data required to design a heating system

Table 2

Recommended heating power and specific heating power of cables

APPLICATION	POWER W/m ²	POWER W/m
DWELLING ROOMS	70-90	10 OR 17
BATHROOMS	80-120	17
CHURCHES, PRODUCTION HALLS	80-120	15 OR 17
PORCHES, RAMPS, WALKWAYS ²⁾	200-250	20 OR 25
GREENHOUSES, SPORTS HALLS	75-150	15 OR 17
COLD STORAGE FOUNDATIONS ¹⁾	15-20	5
GUTTERS, DOWN PIPES ²⁾	-	15, 17, 20 OR 25
METAL PIPES (WATER, SEWAGE) ³⁾	-	≤ 10
ADDITIONAL HEATING (WARM FLOOR EFFECT)	50-70	10, 15 OR 17

¹⁾ Made to order

²⁾ External use only

³⁾ Only as anti-freeze protection

ATTENTION: Electric floor heating requires a detailed design for each case.

For a thermal insulation of medium quality (ceilings, walls, windows, etc.), average value of heating power per sq. metre should be applied, the smallest values may be used for buildings of good thermal insulation ($k \leq 0,4$ W/m K).

Table 3

The smallest distances allowed between cables for various floor types and specific heating power.

FLOOR TYPE	SPECIFIC HEATING POWER			
	10 W/m	15 W/m, 17 W/m	20 W/m	25 W/m
	SMALLEST DISTANCES ALLOWED BETWEEN CABLES (cm) ³⁾			
TILES MARBLE OTHER CERAMIC MATERIALS	7	10	14 ¹⁾	8 ⁴⁾
PCV	8	12	-	-
WOOD (MOSAIC ²⁾ , FLOOR PANELS) TEXTILE LINING	10	14	-	-

Notices:

- ¹⁾ in case of heating driveways, walkways, ramps, and stairs outdoor areas - 7 cm;
- ²⁾ thickness of wood flooring not more than 10 mm;
- ³⁾ cables should only be installed with the minimum gap (as shown in the table) where the temperature controller has a floor sensor;
- ⁴⁾ this distance appropriate to heating driveways, walkways, ramps, stairs and other outdoor areas.

ATTENTION: The distances between cables should not exceed 20 cm in order to prevent creating of areas with too low temperature.

D Design example

The designer's task is to:

- calculate the sufficient specific heating power (Watts per 1 sq. m.) to warm up the compartment (Table 2);
only the "clean" floor surface should be considered for calculation, e.g. surface not covered with a constant equipment such, as furniture without supports, carpets, bathtubs, W.C. or materials stored directly on the floor;
- determine the floor material;
- calculate the specific heating power for selected floor material (Table 2);
- in case of anti-freezing protection, the first step is a calculation of heat losses, and the second step is a selection of the correct heating cable type.

ROOM

For a room of 22 sq. m. floor surface, inside of a building with medium thermal parameters, the basic heating power of 80 W/sq. m is selected (Table 2).

So: $80 \text{ W/sq. m} \times 22 \text{ sq. m} = 1760 \text{ W}$. Example: For a tile floor (the required heating power of the cable is 17 W/m) either one VCD 17/1800 cable set is selected (1800 W heating power, 106 m long).

The furniture will include: one cupboard (2,0 m x 0,6 m) with the entire bottom standing on the floor, one mattress (2 x 3 m). The total uncovered floor surface is $22 \text{ sq. m} - (0,6 \text{ m} \times 2 \text{ m}) - (2 \text{ m} \times 3 \text{ m}) = 14,8 \text{ sq. m}$.

For calculation of distances between the heating cables (in the uncovered part of the floor): this surface is divided by the cable length, for instance:

$14,8 \text{ sq. m} \div 106 \text{ m} = 14 \text{ cm}$. The smallest allowed distances between the cables for a tile floor and 17 W/m specific heating power is 10 cm (Table 3), so the solution is correct. We must notice, that for a wooden floor or for a carpet lining, this distance is 14 cm. For this case we must recalculate with another cable set of a smaller heating power. The missing heating power will be supplemented by an electric convection heater.

BATHROOM

For a bathroom of 13 sq. m. surface, heating power of 100 W/sq. m is selected (Table 2).

The bathroom equipment includes: one bathtub (1,6 x 0,7 m), one shower cabin (1,0 x 0,8 m), one washing machine (0,3 x 0,4 m). The total uncovered floor surface is 13 sq. m. - (1,0 m x 0,8 m) - (1,6 m x 0,7 m) - (0,3 m x 0,4 m) - (0,6 m x 0,4 m) = 10,7 m.

For a tile floor, one VCD 17/1170 set (1170 W, 69 metres) is selected. The distance between cables is: $10,7 \text{ m} \div 69 \text{ m} = 15,5 \text{ cm}$.

For a tile floor and for 17 W/m specific heating power, the smallest distance allowed between cables is 10 cm, so this solution is correct.

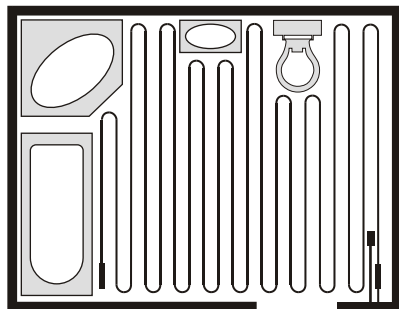

Figure 2

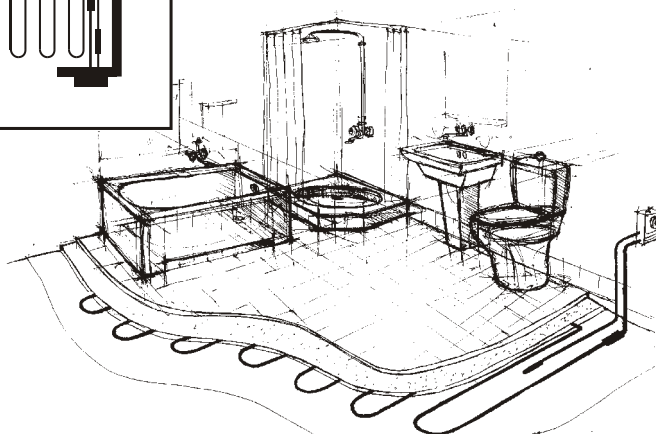

Figure 1

Installation

On an insulation layer of hard styrofoam (FS20, FS30), or of hard mineral wool, a PE coat (moisture insulation) and metal net (for fastening the heating cables) are laid. The net should be made of round wires; the wire thickness should be large enough to provide a sufficient distance between the heating cable and the insulation, for instance: 2 mm wire diameter, 5 x 5 cm net module (Figure 3a, 3c).

If a primer was laid on the insulation, installation tapes may be used instead of metal net (Figure 3d). The heating cable should be laid uniformly over the entire heated surface. If the heated surface is smaller than the compartment floor (as in Figures 1 and 2), special attention must be paid in order to keep the distances between the cables not smaller than given in Table 3.

Both ends of the heating cable (black connectors) must be completely submersed in the mortar. The heating cable is fastened to the net with band clips or a soft wire, and then covered with a sand and cement mortar of minimum 50 mm thickness. A self-levelling mortar may be used. Walking boards are recommended for workers to protect the heating cable from damage. Special care must be taken that the cable is completely covered by the mortar. The heating system may be first switched on not earlier than after the mortar is completely dry (approx. 30 days).

ATTENTION: If a temperature controller with a floor sensor is used, you must remember to put the sensor into a protecting tube (of metal or plastic) so it may be replaced any time. Temperature controllers for bathrooms or other wet compartments should be located outside the compartment (as shown in Figure 2).

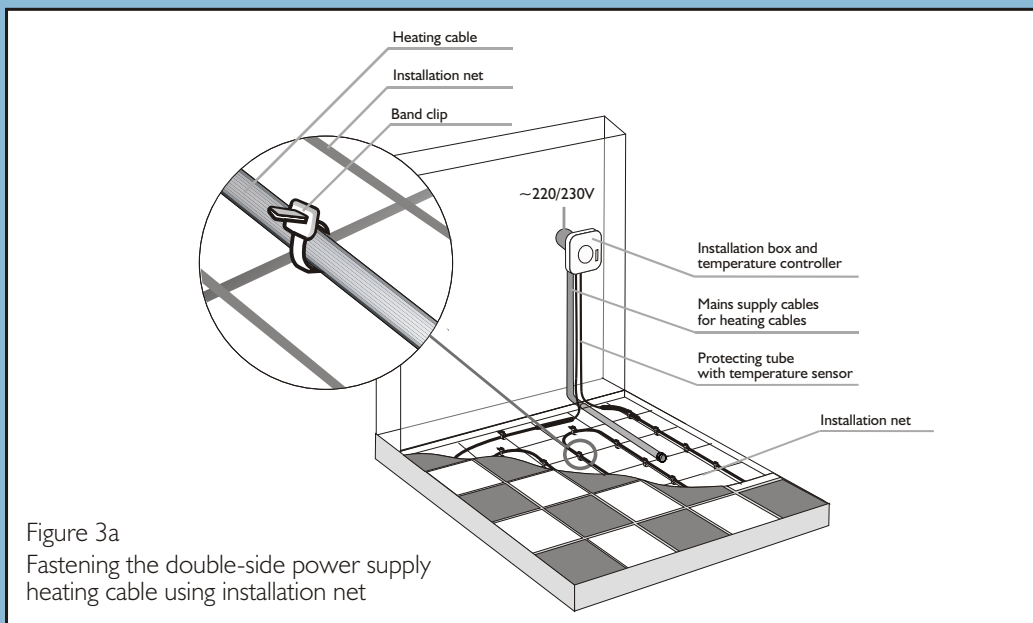

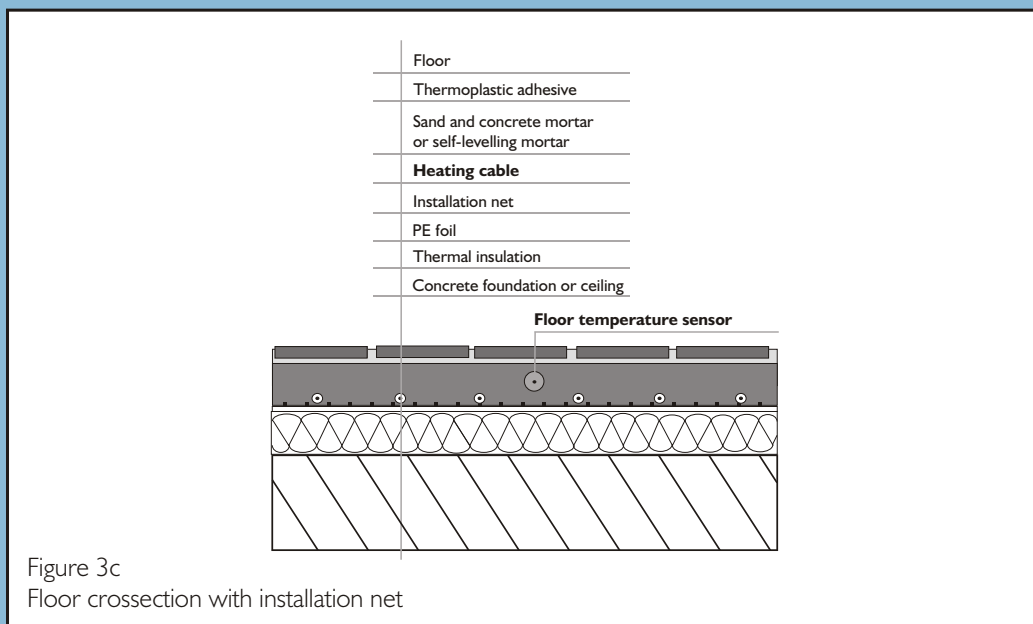
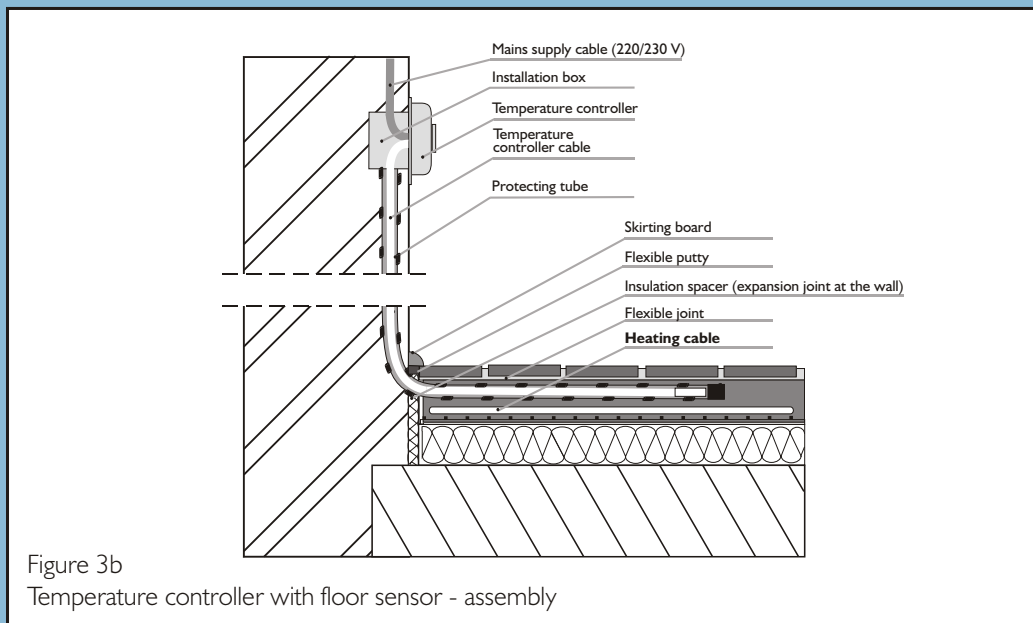

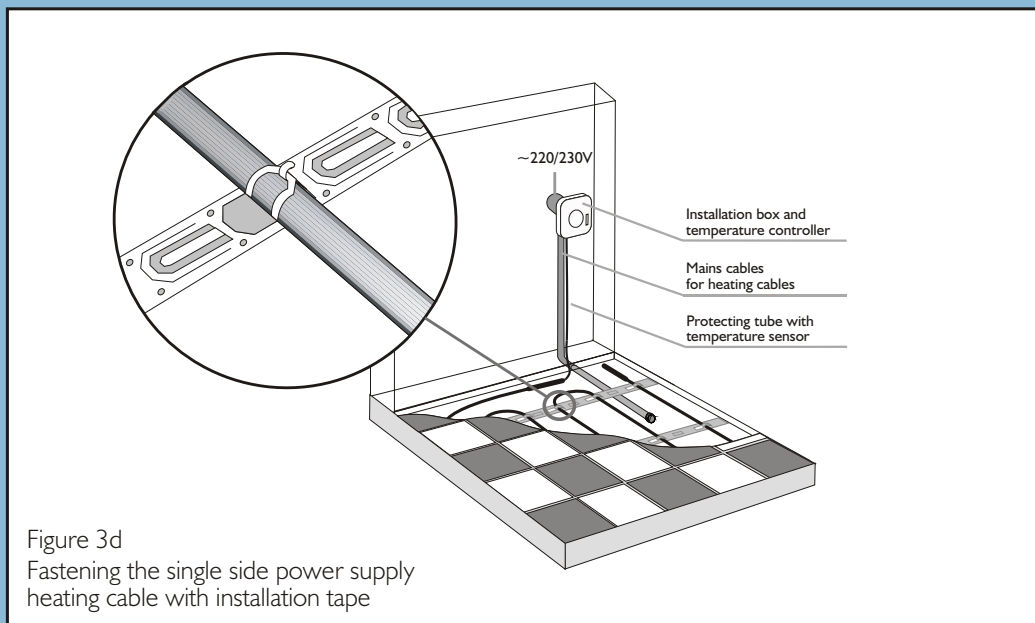

Do not forget the thermal insulation!!! Remember to lay down an insulation (styrofoam or expansion tape of min. 2 mm thickness) between the heated floor and the walls, so that the heat is not absorbed by the walls. Besides, the heating cables must **always** be laid on the insulation. The insulation thickness depends on the floor type. For a floor between storeys, a minimum thickness of 5 cm is required; for cellars or for compartments without a cellar - a minimum of 15 cm is required.

Remember: for a tile floor always use flexible joints to prevent the tiles from cracking.

Connecting the heating cables

Connection of the heating cables to the mains supply should be made via the temperature controller. In case of single-side-supplied heating cables, the heating core end is only connected with the hot conductor (black), and the return conductor is connected with the ground conductor (green and yellow). In case of double-side-supplied heating cables, one end of the heating core is connected with the cold conductor (black) whereas the other end is connected with the neutral conductor (blue). Both ends of the heating cable screen are connected with the ground conductor (green and yellow). The temperature controller should be installed in an installation box. The following cables should be led under the plaster work to the installation box: the mains cables (220/230 V), the "cold" conductors of the heating cable, and the floor sensor cable (if a floor sensor or a floor and air temperature sensor is used). The sensor with its cable should be put into a protecting tube, which is to be sealed afterwards. The protecting tube must not be 90° bent, the tube must keep the arc shape (Figure 3b).

The selection of place for the installation box is important due to both **esthetic** (the temperature controller is visible on the wall) as well as **practical** reason (as the "cold" conductor is 2.5 metre long, the heating cable must be so configured, that the "cold" conductor allows for a connection with the temperature controller).

ATTENTION: The temperature sensor must be located in the same distance from both the cables. The protection conductors of the heating cable (green and yellow) should be connected with the mains protecting conductor (green and yellow) using the clamp at the controller. If such a clamp does not exist, the connection is to be made inside of the installation box.

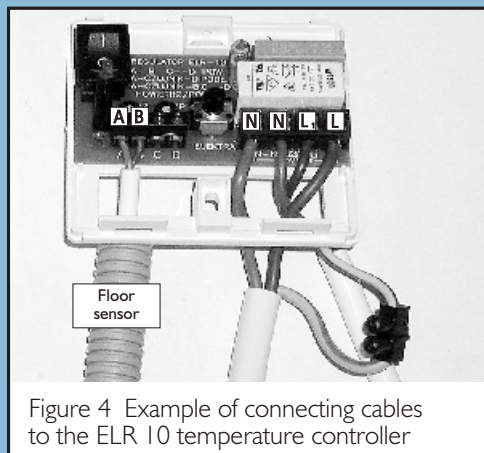

Figure 4 Example of connecting cables to the ELR 10 temperature controller

S Shock protection

A copper screen grounded or connected to the ground wire (PE) provides the complete safety of operating the heating cables. A differential ($D \leq 30 \text{ mA}$) shock-protecting switch should be used in the heating installations.

The switch-off time must be shorter than 0.2 second. A single differential switch may be used for numerous receivers. After the installation is accomplished, the current leakage must be measured. The vector sum of leakage currents at normal operation of the circuit equipped with a differential switch must be smaller than 50% of the switching-off differential current. The insulation resistance of the heating cable measured with a magneto of 1000V nominal voltage must not be smaller than 0.5 MW..

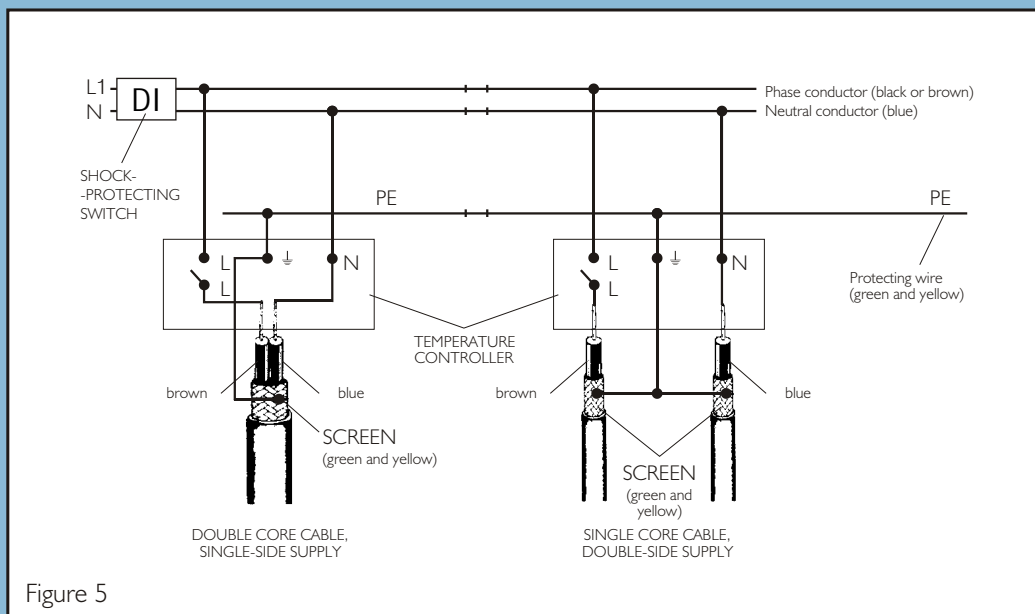

Figure 5

Operation

The electric floor heating is very easy to operate, but you must remember that the entire floor surface is the heat source for the room. Besides, you should neither change the furniture layout, nor the room assignment.

Such changes would deteriorate the heat transmission from the floor. You should neither change the floor finish, nor put on the floor large objects without any supports which would tightly adhere to the floor or lock air underneath (like kitchen cabinets, etc.). No carpets should be laid on the heated floor, which have not been considered in the floor design. Any openings in the floor may only be drilled after the cable has been located based on the "as-built" documentation or with an appropriate device.

In case of any doubt please contact the technical department of our company.









N

Notes





Our program includes:

- HEATING CABLES AND MATS,
ELECTRONIC TEMPERATURE CONTROLLERS  **ELEKTRA®**
- CONVECTION HEATERS  **ADAX**
 **atlantic**
- STORAGE HEATERS **Olsberg** 
- SELFREGULATING HEATING CABLES  **ELEKTRA®**
Raychem tyco
- HEAT RECOVERY VENTILATION,
CENTRAL VACUUM CLEANERS  **FLEXIT®**
For a healthier indoor environment
- BATHROOM HEATERS  **ELEKTRA®**
- WATER HEATERS.....  **atlantic**



ELEKTRA®



SILVER ACE '93



BRONZE HELMET '97



SILVER HELMET '98



GOLD HELMET '97



GOLD MEDAL
MTP Poznan '2001



ul. Marynarska 14
02-674 Warszawa, Poland
tel.: (+48 22) 843 32 82
fax: (+48 22) 843 47 52
e-mail: office@elektra.pl
www.elektra-heating.com